

INSTALLATION LUBRICATION MAINTENANCE

GEARBOX MANUAL



Hydraulics, Inc.

3905 W. 9th Street • Trainer, PA • 19061
(610) 497-0190 • Fax (610) 497-0194
info@saihyd.com www.saihyd.com

INSTALLATION

In order to guarantee troublefree operation, it is important to follow some basic principles:

The frame or structure accepting the gearbox must be rigid and of sufficient thickness

The mating surfaces have to be machined; making sure the bearing surface is concentric and perpendicular to gearbox's axis. The bore accepting the gearcase pilot must be machined and toleranced to an H8 metric tolerance. Gearboxes with internal splined output shafts cannot bear any shaft loads and require high accuracy regarding the perpendicularity and concentricity between the bearing surface and the driven shaft. The driven shaft must be self supported and has to be carefully aligned with the gearbox axis.

For mounting the unit, use bolts of at least 8.8 quality. Tighten with torque wrench to 80% of bolt yield strength. If the unit has to transmit very high torque or if there are inversions or shocks, then use bolts of 10.9 or 12.9 quality tightening to 80% of yield strength. Always use all bolt holes on the flange. Larger gearboxes, sizes 1800 to 15000 have to be pinned in addition. The required spiral elastic pins are delivered with the unit. The larger gearboxes have two (2) pilots and both must be used if the shaft load exceeds 50% of admissible load.

The mounting position should guarantee free access to the plugs in order to facilitate oil level checking and oil replacement, see Tab. 2. In case of vertical mounting, extension tubes and compensating reservoirs may be needed. See diagrams on the following page.

If the unit is driven by belt, chain or coupling, then align carefully.

Shaft seals and breather plugs must not be painted.

Moving parts, such as input and output shafts, pinions, couplings, vee-belts, etc. have to be protected by the customer in a suitable manner and in compliance with all applicable safety rules and regulations. SAI shall not be liable for any damages to persons or things due to lack of observance of these guidelines.

The mounting positions O and P, as well as position D for gearboxes with brake, must be specified when ordering. Refer to Tab. 2 for mounting positions.

SETTING IN MOTION

The gearboxes should be started up, if possible, without load and at low speed. If there are no problems, for example, vibrations or excessive noise, the gearbox can be run up to the normal load conditions. Check for oil leaks and oil level after trial run.

Tab. 1 Lubricants

$(^{\circ}\text{F} = 1.8 \times \text{C}^{\circ} + 32)$

AMBIENT TEMP.	-20°C...+5°C	+5°C...+40°C	+30°C...+65°C	+45°C...+70°C
VISCOSITY	°E/50°C	7.3	10.8...12.5	15...18
	ISO VG	100	150	220
AGIP	BLASIA 100	BLASIA 150	BLASIA 220	BLASIA 320
BP	ENERGOL GR-HP 100	ENERGOL GR-HP 150	ENERGOL GR-HP 220	ENERGOL GR-HP 320
CASTROL	ALPHA SP 100	ALPHA SP 150	ALPHA SP 220	ALPHA SP 320
CHEVRON	NL GEAR COMPOUND 100	NL GEAR COMPOUND 150	NL GEAR COMPOUND 220	NL GEAR COMPOUND 320
ELF	REDUCTELF SP 100	REDUCTELF SP 150	REDUCTELF SP 220	REDUCTELF SP 320
ESSO	SPARTAN EP 100	SPARTAN EP 150	SPARTAN EP 220	SPARTAN EP 320
FINA	GIRAN 100	GIRAN 150	GIRAN 220	GIRAN 320
IP	MELLANA 100	MELLANA 150	MELLANA 220	MELLANA 320
MOBIL	-	MOBILGEAR 629	MOBILGEAR 630	MOBILGEAR 632
SHELL	OMALA EP 100	OMALA EP 150	OMALA EP 220	OMALA 320
TOTAL	CARTER EP 100	CARTER EP 150	CARTER EP 220	CARTER EP 320

Tab. 2 Plug Positions

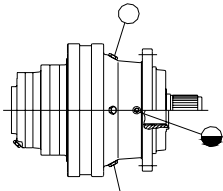
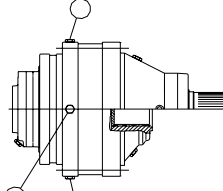
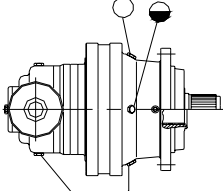
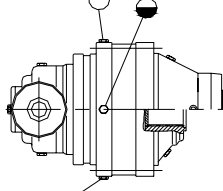
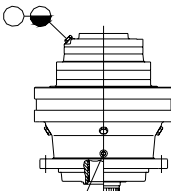
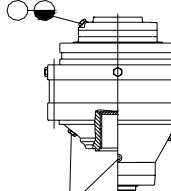
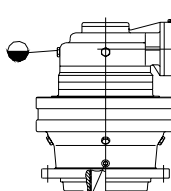
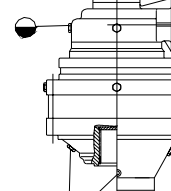
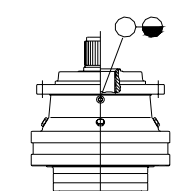
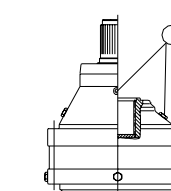
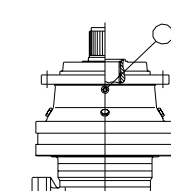
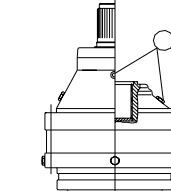
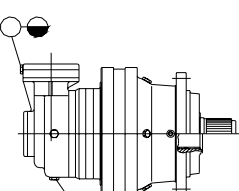
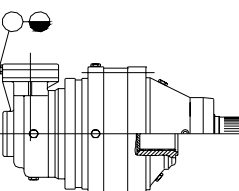
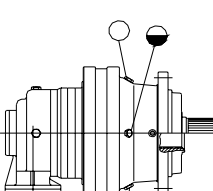
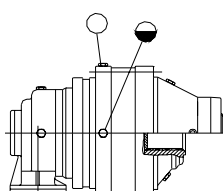
	IN LINE GEARBOXES		RIGHT ANGLE GEARBOXES	
	RES 100...RES 1300	RES 2000...RES 8000	RES 300...RES 1300	RES 2000...RES 8000
HORIZONTAL				
VERTICAL				
				
HORIZONTAL				

○ Oil Filling & Breather ◐ Oil Level ● Oil Drain

LUBRICATION



Oil Quantity (Qts.)

GEARBOXES		IN LINE - EXT.			IN LINE - INT.			RIGHT ANGLE - EXT			RIGHT ANGLE - INT		
		Pos. A	Pos. O	Pos. T	Pos. A	Pos. O	Pos. T	Pos. B	Pos. P	Pos. U	Pos. B	Pos. P	Pos. U
100/100R 200/200R	1	0.5	1	1	0.5	1	1	N/A			N/A		
	2	1	2	1.5	1	2	1.5						
	3	1.5	2.5	2	1.5	2.5	2						
	4	2	3	2.5	2	3	2.5						
300/400/500	1	1	2	1.5	1	2	1.5						
	2	1.5	3	2.5	1.5	3	2.5	3.5	7	5.5	3.5	7	5.5
	3	2	3.5	3	2	3.5	3	4	7.5	6	4	7.5	6
	4	2.5	4	3.5	2.5	4	3.5	5.5	8	6.5	5.5	8	6.5
300R/400R 500R	1	1	2	2	1	2	2						
	2	1.5	3	2.5	1.5	3	2.5	3.5	7	5.5	3.5	7	5.5
	3	2	3.5	3.5	2	3.5	3.5	4	7.5	6	4	7.5	6
	4	2.5	4	4	2.4	4	4	5.5	8	6.5	5.5	8	6.5
800R	1	2	3	3.5	2	3	3.5						
	2	3	4	4	3	4	4	7	8	8	7	8	8
	3	3.5	4.5	4.5	3.5	4.5	4.5	5	9.5	9.5	5	9.5	9.5
	4	4	5	5	4	5	5	6	9.5	9.5	6	9.5	9.5
1000 1300/1300R	1	3	4.5	4	3	4.5	4						
	2	4	6	5	4	6	5	7	11	10.5	7	11	10.5
	3	5	9	7	5	9	7	8	13	11.5	8	13	11.5
	4	5.5	9.5	7.5	5.5	9.5	7.5	8.5	13.5	12	8.5	13.5	12
1800/1800R 2000/2000R	1	3	5	4	2.6	4.6	3.6						
	2	4	7	5	3.6	6.5	4.6	7	13	10	6	12	9
	3	5	8.5	7	4.6	8	6.5	8	14	11	7	13	10
	4	5.5	9	7.5	5	8.5	7	8.5	14.5	11.5	8	14	11
3000/4000	1	4.5	8	7	4	7.5	6.5						
	2	6	11	9	5.5	10	8.5	14	26	23	12	25	24
	3	9	16	14	7	13	11	9	18	14	8	16.5	12.5
	4	9.5	16.5	14.5	7.5	13.5	11.5	11	16	22	10	20.5	14.5
6000	1	5.5	10	8	4.5	9	7						
	2	7.5	14	10	6.5	13	9	9	18	13	8	17	12
	3	9	16	14	8	16	13	11	22	16	9.5	20	14
	4	10	17	15	9	17	14	13	25	18	11.5	23	16
8000/10000	1	8	15	12	6.5	13	10						
	2	9	17	14	7.5	15	12	12	21	17	10.5	19	15
	3	11	20	17	9.5	18	15	17	32	29	15	30	27
	4	12	21	18	10.5	19	16	14	27	20	12	25	18
15000	1	20	35	30	20	35	30						
	2	25	40	33	25	40	33	27	44	36	27	44	36
	3	28	45	38	28	45	38	33	55	48	33	55	48
	4	30	47	40	30	47	40	33	55	45	33	55	45

The reducers are delivered without oil. Before starting up, the gearcase must be filled with EP-oil. For standard application use viscosity grade 150 (according to ISO). Tab. 1 shows suitable lubricants for a wide range of ambient temperature.

The proper oil level has to be checked with the level plug. Plug and mounting positions are shown in Tab. 2.

The required oil quantity depends on reduction ratio and the input flange. The quantity necessary for various mounting positions can be gathered from the certificate accompanying the gearbox. It is important that the replacement of the lubricant is carried out according to the changing intervals as described.

The oil temperature must not exceed 90°C. For continuous duty applications an oil cooling system must be installed. If the transmitted power exceeds the thermal power limit. Contact the Technical Department for information.

MAINTENANCE

The only necessary actions to be taken are to replace the lubricant and to check the oil level. If necessary, fill up with same type of oil which is in the gearcase. Check for oil leaks.

The first oil replacement is required after 100 running hours and every 2500 running hours thereafter, this must be performed at least once every year. If synthetic oils are used, changing intervals may be different. Contact Technical Department for details.

To avoid deposits, we recommend replacing the lubricant when hot. Please wear protective apparel (gloves, goggles, etc.) when changing the lubricant. The surface of the gearbox and the oil could be very hot. Please protect the environment and obey all applicable rules and laws in your area.

